

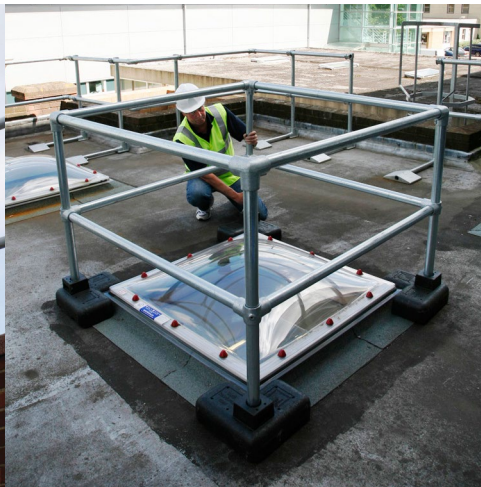

SEPARATING PEOPLE FROM HAZARDS

Fall Protection Solutions



- PERMANENT AND TEMPORARY PORTABLE OPTIONS AVAILABLE
- INDEPENDENTLY TESTED, MEETS OR EXCEEDS SAFETY STANDARDS
- NO WELDING, BENDING, OR THREADING OF PIPE
- GALVANIZED FINISHES MAKE INSTALLATIONS VIRTUALLY MAINTENANCE FREE



CSI 077200
January 2013

Independently tested to
OSHA Standard 29 CFR 1910.23
Ontario OHS Act
Meets ANSI Standards



the fall protection solution

At KEE SAFETY, our specialty is railing solutions. For over 75 years, we have been designing our quality components and barriers for safety solutions. We strongly believe that our railing solutions provide maximum fall protection for your people at heights. When you need a safe, reliable, durable and versatile fall protection solution, choose KEE SAFETY.

Fall Protection Survey

We can provide a complete turn-key fall protection solution for you. The process starts with the Fall Protection Survey which involves a site visit to your facility.

From the survey, we will develop a custom Fall Protection Survey Report to inform you of areas of safety concern. The report, complete with color photographs, conveys our recommendations of how to address these areas and includes references to all relevant safety regulations. If you would like, we can include risk assessment of all your existing fall hazards.

After the areas of safety concern are evaluated, we will give you a materials quotation for any fall protection solutions we recommend.

Installation

Installation can be done by our team or your own. If you choose our team, installation will be charged accordingly. If you decide to install the system yourselves, we can provide you with the shop drawings that show the locations of all the components. We can provide training for your installation team to communicate all of the necessary recommendations to complete the installation correctly. This training can be done at your own facility or at our training center in Buffalo, NY.

System Certification

We offer an optional Certified Installation Service which consists of a site visit after the installation is complete. You will receive a report that describes the installation and denotes any corrections that need to be made for the most effective fall protection. When the installation is completed correctly, you will receive a certificate confirming manufacturer approval.

We set the standards

- OSHA Standard 29 CFR 1910.23
- OSHA Standard 29 CFR 1926.501, CFR 1926.502
- Canadian National Building Code 4.1.10.1(1)(e), 4.1.10.1(2), 4.1.10.1(4)
- Ontario Building Code Section 4.1.10.1(1)(b), 4.1.10.1(2), 4.1.10.1(4)
- HSG-33 Health & Safety in Roof Work
- HSE Specialist Report No 15: 1988
- HSE Sheet 21 "Working on Flat Roofs Protection Against Falls"
- BS 6399: Part 2 1995 Wind Code
- EU Directives & CDM Regulations
- BGV A1: 2000, BGG 928 & BGR 184
- Health, Safety & Welfare Regulation 13 "Falls or Falling Objects" 1992
- NFE 85-003
- EN ISO 14122: PT3
- EN 13374
- International Building Code 2006
- ANSI/ASSE A1264.1-2007 Standard
- Wind load tested
- Earthquake & collision results

Warranty

Our standard warranty on all fall protection components is one year. We also offer an extended warranty service to be purchased additionally, which can consist of up to a five-year warranty on all of the components. This extended warranty includes a site visit within one year following the completion of the installation. During the site visit, the installation will be inspected and recommendations will be made for other areas of safety concern, if applicable.



Safety

KEE SAFETY Fall Protection Systems not only meet, but exceed current safety requirements for maximum rooftop fall protection. KEE SAFETY Fall Protection Systems use components that are TÜV tested and approved. System components are fitted with anti-slip rubber pads for safety and to protect the roof membrane. Integral toe board may be added for full health and safety compliance.

Durability

KEE SAFETY Fall Protection Systems use components that are galvanized, providing long lasting rooftop fall protection you can depend on. All pipe is galvanized to ASTM A53. All components are galvanized to meet the requirements of BS EN ISO 1461:199. Our systems utilize reliable KEE KLAMP components which provide strong, rigid, virtually maintenance free connections, featuring case hardened steel set screws with KEE KOAT corrosion resistance.

Versatility

KEE SAFETY Fall Protection Systems employ a pre-fabricated modular design that allows you to reconfigure your system on site, with ease, if needed. Sections can be added to, or taken down and assembled on site. A variety of uses include skylight protection, walkway demarcation, stairwell protection and more. Our solutions are compatible with almost all variations of flat roofs (up to 5 degrees), be they circular, square, rectangular or multilevel. All products are available from our warehouse or through authorized installers.

Simplicity

KEE SAFETY Fall Protection Systems have a unique modular design that takes the complexity and cost out of rooftop fall protection. Minimum number of components eases installation. No drilling, special anchoring or penetration of the roof membrane. No welding, bending or threading required on site, and no specialty tools are needed.

OSHA Compliant

The KEE KLAMP components, and specially designed KEEGUARD components, when used to construct the KEEGUARD Railing System, a 42" high guard railing, will meet or exceed the requirements of the OSHA Safety Standard of a single 200 lb. load applied at any location and in any direction along the top of the rail when the correct specification of pipe is used and the correct method of design is employed. The integrity of the structure to which the system may be attached and the fixings used may need to be reviewed by a structural engineer to ensure they will meet the imposed load requirements.





permanent, free standing
roof edge railing system that
does not penetrate the roof
membrane

KEEGUARD Counterbalance Assembly

CB4 and CB3 assemblies are used for end uprights when there is no tie into the building or at the end of a run over 13 feet. For runs less than 13 feet, please contact us.

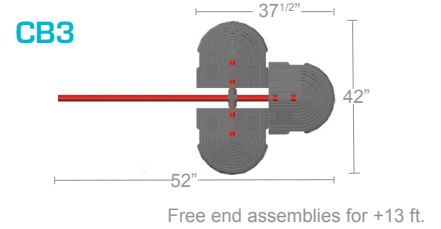
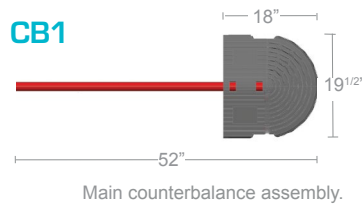

Recycled PVC Counterbalance

- Each CB weights 30 lbs
- Carrying handles molded into design
- Reflective labels on each weight
- Surface promotes traction and grip
- Made from 100% Recycled PVC
- Size: 18 x 20 x 3 inch

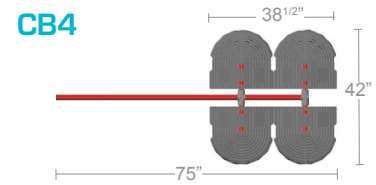

KEEGUARD Main Upright

Our KEEGUARD uprights are preassembled for fast on-site installation.

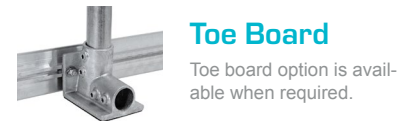
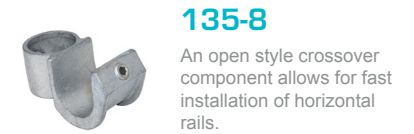
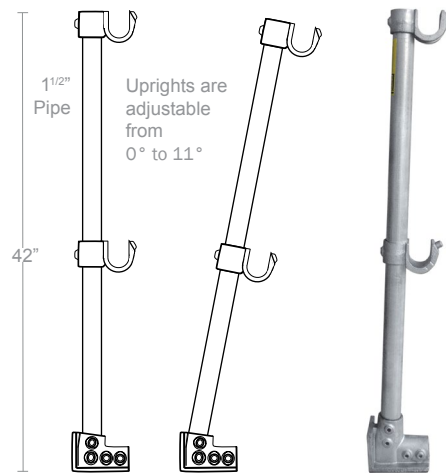

KEE KLAMP Components

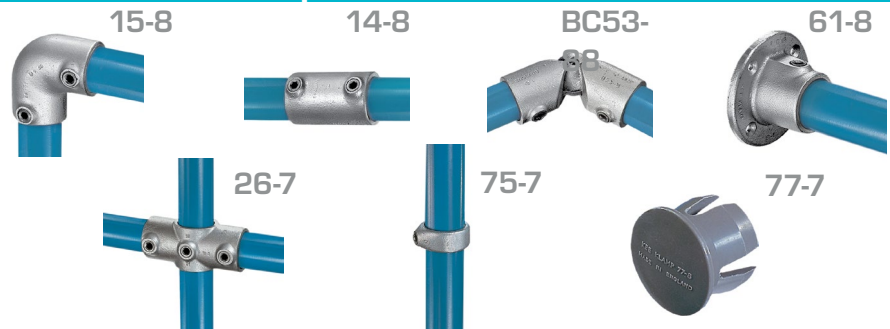

KEE KLAMP components make the basic building of KEEGUARD configurations straight-forward and versatile. The components above are the most commonly employed in KEEGUARD fall protection systems.

KEEGUARD Drawings

Examples of D-returns, wall attachment, and parapet protection. Just contact the KEEGUARD engineering team at KEE SAFETY for custom configurations and technical assistance.

- Use CB4 and CB3 assemblies for end uprights not attached to the building
- Dimensions of D-Return and distances between uprights are maximum allowable distances

Fig. 2

Wall attachment

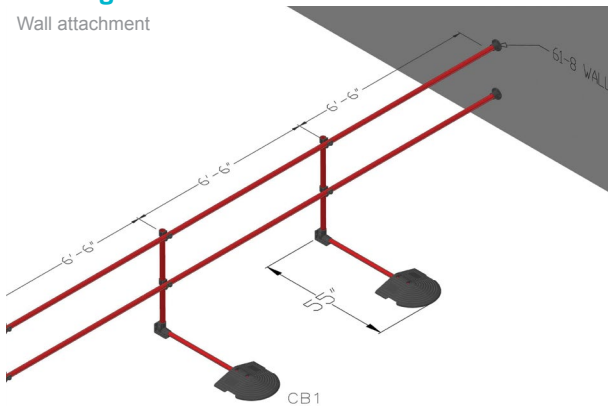

Fig. 1

Straight 29' run with D>Returns

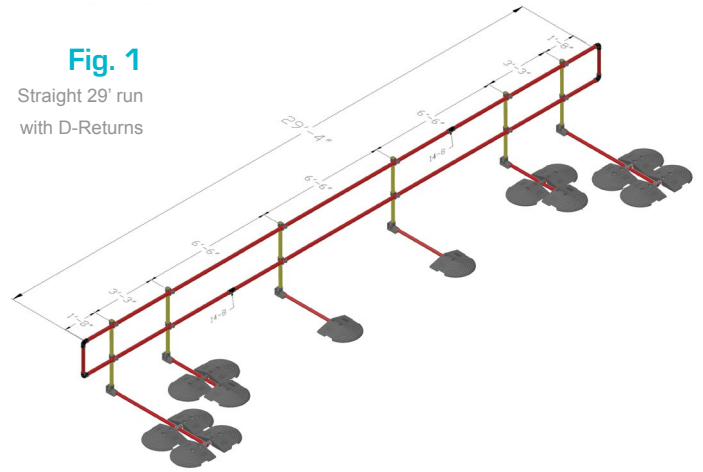

Fig. 3

L-shaped 29'x13' with D>Returns

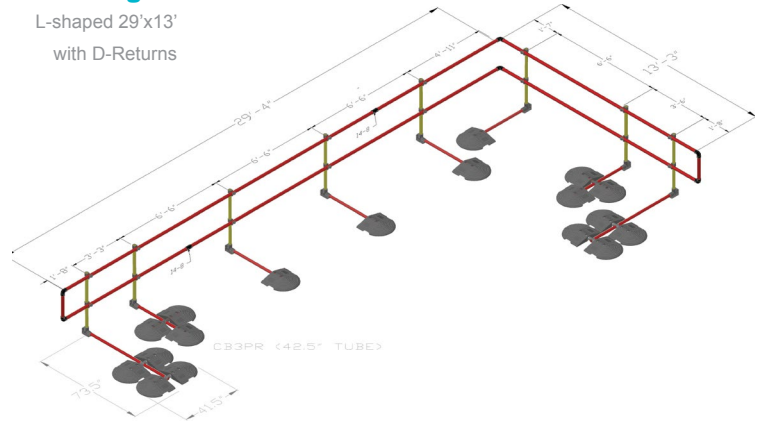

Fig. 4

16' Straight Unrestrained

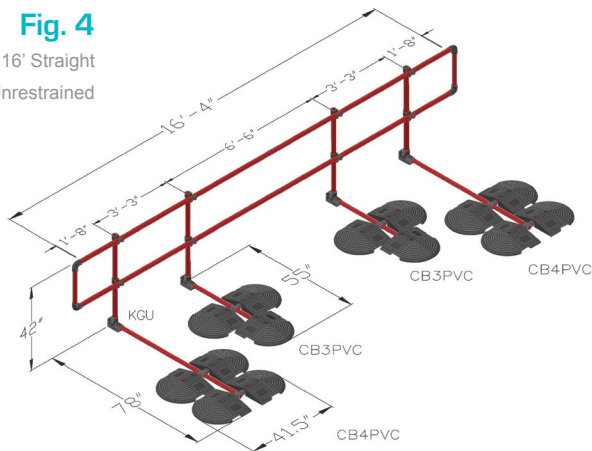
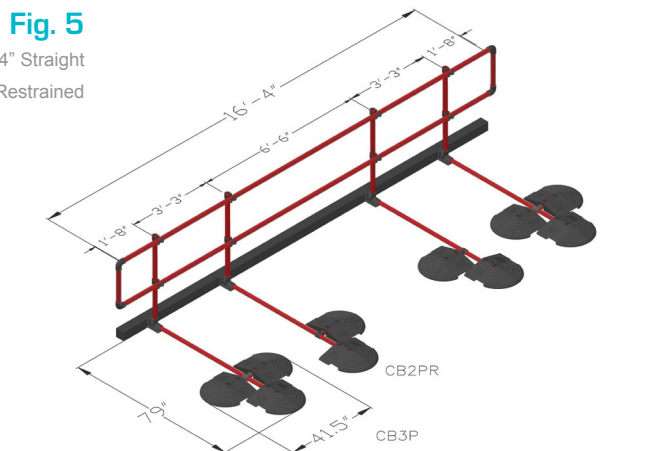

Fig. 5

16' -4" Straight Restrained



Sold only as a complete system.

Custom Color

The KEEGUARD PVC counterbalance are available in a standard gray color. KEEGUARD PVC counterbalances are also available in yellow. Please contact KEE SAFETY for details.

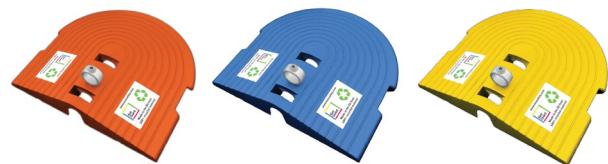

standing seam



Here at KEE SAFETY, we've put together a unique railing system for standing seam metal roofs system that is OSHA compliant. This custom designed guard rail provides proper access to rooftop equipment for maintenance or inspection, provides any needed perimeter protection, and also accommodates proper ladder access. With our standing seam systems, there is no drilling, special anchoring or penetration of the roof. No welding, bending or threading on site, and no specialty tools are needed. It doesn't get any easier than that!

Versatile

The use of KEE KLAMP components enables KEEGUARD to meet unique design requirements and nonstandard applications. The horizontal baseplates are custom fabricated to meet the exact specifications of your standing seam metal roofs.

Fig. 1

KEEGUARD standing seam 24' run with d-returns

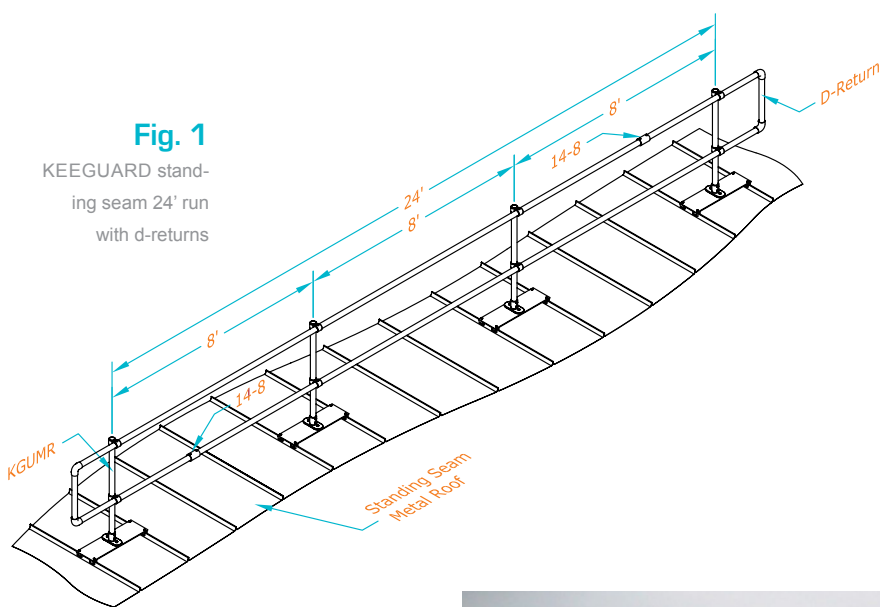
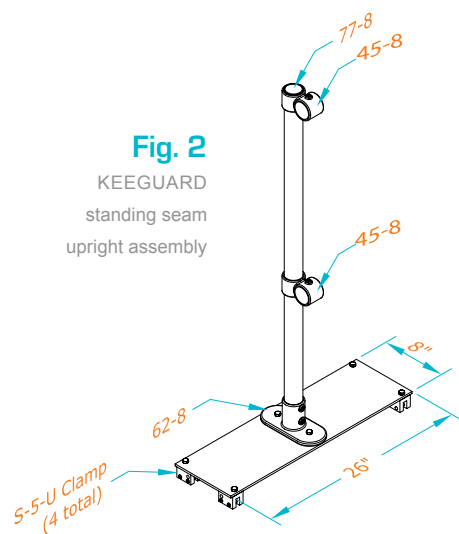

Fig. 2

KEEGUARD standing seam upright assembly



Configuration

Four S-5U clamps are bolted to a galvanized steel base plate, and using simple set screws, the S-5U clamps attach securely to the standing seams without puncturing the metal roof. A KEE KLAMP Type 62 component affixes to each metal base plate in the system to support the uprights. Our open-style crossover component, Type 135-8, speeds installation of horizontal rails on all KEEGUARD Fall Protection Systems. All components are galvanized for corrosion resistance and minimum long term maintenance.

Sold only as a complete system.





Portable Roof Edge Protection

KEEGUARD Contractor offers a new and innovative approach to portable and temporary railing systems. Since the system is free standing, there is never a need for hardware connections to the rooftop or working surface. KEEGUARD Contractor meets all OSHA Standards for permanent railings, including OSHA Standard 29 CFR 1926.500 with returns in place. (As shown below) Fig. 1



Fig. 1

KEEGUARD
Contractor configuration

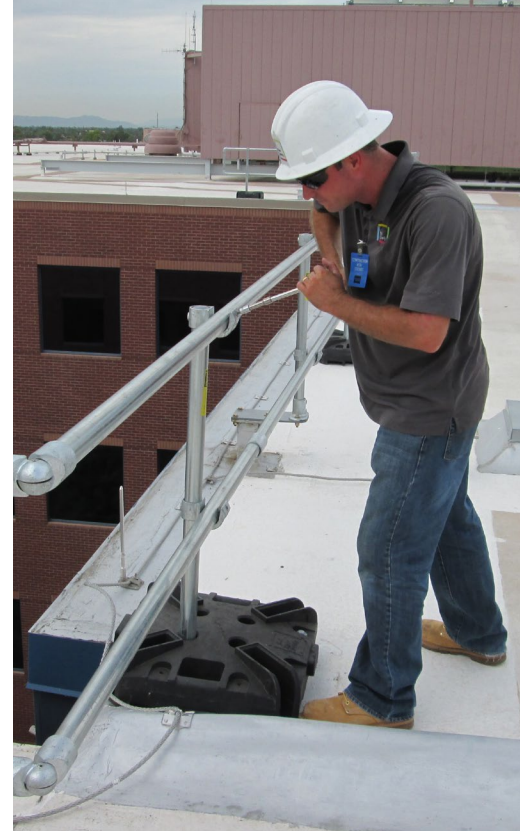

Configuration

The uprights are secured in the bases by set screws, making the system as solid as permanent railing. Assembly is made simple by using a torque wrench or hex key. A railing section consists of two uprights and two horizontal rails. The minimum system configuration consists of three railing sections and four base plates, all with a galvanized finish ensuring a long life of the system. Powder coating in safety yellow is available.

Sold only as a complete system.

Contractor Base Plate

- Strong, galvanized finish
- Weight constructed from recycled PVC to protect roof membrane
- Four upright sockets make almost any perimeter configuration possible
- 98 lb. base ensures stability
- Ergonomically designed handles
- Complete with slots for optional 2"x 6" toeboard

Kee® Mark



Demarcation

KEE MARK is a sturdy, durable, and cost effective portable warning line, for indoors and out. The simple modular design incorporates durable galvanized KEE KLAMP components and galvanized uprights that stay in place with a hidden set screw. The heavy-duty nylon mesh flags are available in safety orange or safety yellow. The stainless steel wire cable is vinyl coated for long term outdoor use in safety yellow for greater visibility. The cables are connected to the uprights with stainless steel shackles which makes adjusting the layout very easy. The removable bases are made of solid heavy duty recycled rubber. KEE MARK is a demarcation solution that is engineered to stand its ground, job site after job site. Meets OSHA standard for warning lines.





safety barrier system for safe egress and ingress through hatches in roofs or floors

The Safety Solution for Hatches

The KEE HATCH safety railing system is designed for safe egress and ingress through roof access hatches and for protection of the roof opening while the hatch is open. Our new safety gate ensures protection around the entire opening. KEE HATCH is designed as a compliment to our KEEGUARD Roof Edge Protection System to provide a complete OSHA compliant, durable, and long lasting solution. KEE HATCH is engineered in the USA and meets the most stringent safety standards.



Simple Design

Our design concept is simple: use strong structural tube and KEE KLAMP components. This simple concept makes our KEE HATCH systems flexible enough to fit any hatch configuration. We only use galvanized fittings and pipe so that your rooftop system is corrosion resistant and built to last.

- Modular construction speeds installation
- Galvanized finish for corrosion resistance
- Rails serve as grab bars for easy roof access

Easy Integration

We have designed seven different solutions that are suited to fit any hatch. KEE HATCH is designed as a compliment to our KEEGUARD Roof Edge Protection System, but it also integrates beautifully into any existing rooftop systems because of its unrivaled versatility.

- 7 versatile systems available
- Compliments KEE GUARD Roof Edge Protection
- Integrates easily with existing openings and ladderways

OSHA Compliant

KEE HATCH meets OSHA standards 29 CFR 1910.23 and 29 CFR 1910.66. The former requires that the exposed sides of openings in roofs or floors have some form of guardrail protection. When the hinged cover for an opening is left up, the exposed sides must be appropriately protected.

- Exceeds minimum strength requirements for railings
- Pre-tested against standards
- Safety Gate option ensures safety around entire opening

Floor Hatch

Part of the KEE HATCH family of products, the FLOOR HATCH Safety Railing is designed for safe egress and ingress through floor access hatches and for protection from the floor opening while the access door is up. It meets OSHA Standards CFR 29 1910.23 and 29 CFR 1910.66.



Configuration

The railing system uses the industry leading KEE KLAMP components and is easy to assemble. The FLOOR HATCH Safety Railing kits are made with either galvanized 1-1/4" pipe or anodized aluminum 1-1/2" pipe for all hatch sizes. A two sided kit can be ordered for a hatch that backs to the wall. The FLOOR HATCH Safety Railing can also be customized to accommodate a toeboard if needed.

Installation

For permanent installation, drill 2 holes for each base component (Type 62, Fig 1) and use lag bolts size 3/8" x 2 1/2" and lag shields to fix railing bases in place (lag kits sold separately). For a removable installation, use ground socket components (Type 66, Fig. 2) that are installed flush with concrete.

Fig. 1

KEE KLAMP Type 62 - Standard Base Flange for use on solid surfaces



Fig. 2

KEE KLAMP Type 66 in-floor base fitting designed for use in concrete. A topside set screw locks the pipe.





skylight guard rail system,
fits skylights, roof lights, and
dome lights with curbs

The Safety Solution for Skylights

Our freestanding KEE DOME system does not penetrate the roof membrane. The heavy duty rubber base keeps the safety railing in place. KEE DOME uses industry leading KEE KLAMP components which are galvanized, making the system long lasting and virtually maintenance free. KEE DOME has been independently tested to OSHA Standard 29 CFR 1910.23.

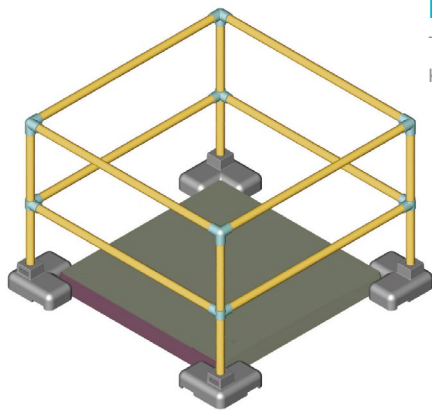
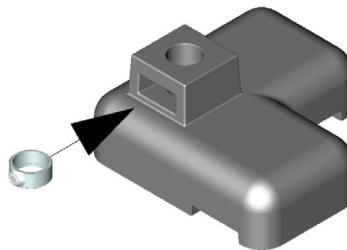

Fig. 1

The maximum footprint for Kee Dome is 8' x 8'

Fig. 2

A clamping ring is inserted into the base unit to lock the upright



Configuration

KEE DOME includes upright posts, horizontal rails, and specialized corner connectors or "feet" made of recycled PVC. The upright posts are locked into position within the base units using clamping rings. The resulting structure is safety compliant, remains completely free-standing, and eliminates the risk of damage to the roof membrane.

Installation

Using standard tools, two workers can install a 8'X 8' KEE DOME in an hour. KEE DOME can be adapted to inclined roofs up to 5 degrees. When installing KEE DOME, all set screws should be tightened to 29 lbs/ft.

Skylight Fall Protection

- Constructed of rigid galvanized pipe
- Does not block light
- Simple customization



screens



screens for curb style,
standing seam, and rib/cor-
rugated metal roof skylights

SKYLIGHT
SCREENS



Quality

Made of galvanized or stainless steel, our skylight screens are available in a range of sizes and styles.

- Curb Style: full range of sizes from 12" x 12" to 70" x 120"
- Standing Seam Roofing: applications are 24" x 120"
- Rib/Corrugated Roofing: applications are 36" x 120" to fit a standard 36" x 120" skylight
- Also available in custom sizes

personal protection solutions

KEE SAFETY has a growing portfolio that is composed of a range of personal solutions that are designed to enhance personal safety when working from heights. Each of these products are tested and approved by ANSI, CSA, NIOSH and OSHA.

KeeLine is a wire based personal system for roof installation or horizontal overhead applications on structures. This is a permanent alternative to the Wireanka system.

The **Kee Anchor** range is designed for use where the installation of collective protection or permanent anchor devices are not viable.

The **Weightanka** is a portable deadweight anchor

The **Wireanka** is the first anchor device to be approved for use as supports for class C horizontal life lines.

A perfect complement to all of our roof top safety systems is the **Kee Walk** system. This is a modular system that provides a safe, anti-slip levelled walking surface. It can be used on flat, barrel and sloping roofs. The system features steps and traverse options.

Permanent Solutions

For protecting personal while working from heights with a permanent fix **KeeLine**, a horizontal safety line, and **Kee Walk**, a modular walkway system, are the optimal solutions. Secured to the rooftop via clamps and anchors, these systems are designed for quick and easy installation that are cost effective and labor saving.



Temporary Solutions

When the matter in question requires a temporary fix the **Weightanka** and **Wireanka** systems are perfect solutions. The modular, non-penetrating dead weight anchor fall prevention systems can be used in conjunction with horizontal safety lines, and rope access work.



Weightanka

A KEE SAFETY PRODUCT

Wireanka

A KEE SAFETY PRODUCT

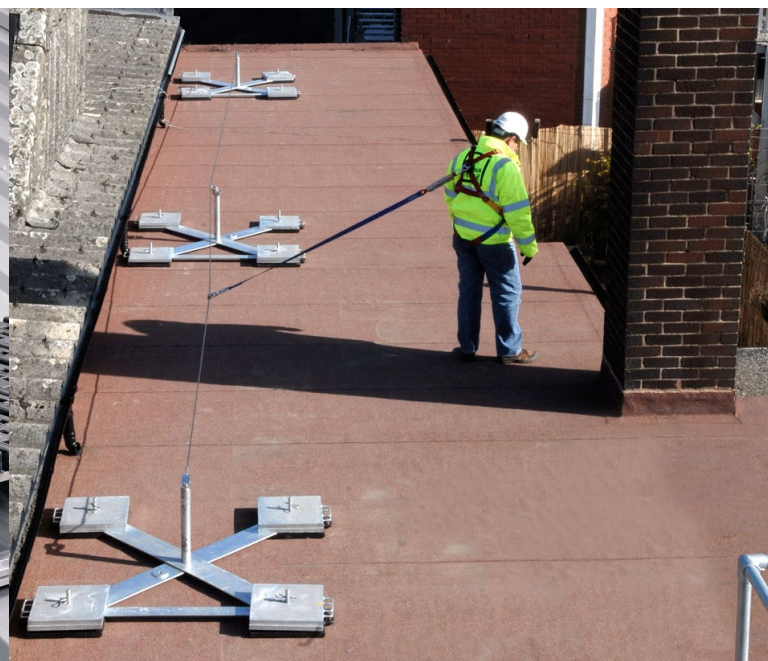



horizontal safety line providing continuous protection for working at heights by either mounting directly onto a roof surface or onto the building structure

KEELINE is a 5/16 inch Grade 316 stainless steel wire system with electro-polished brackets, detachable travellers and powder coated anchors that provides flexible, continuous protection for multiple users working at height. The system incorporates an Inline Shock Absorber that minimizes the loads to an acceptable level for both the user and structure in the event of a fall. The Inline Shock Absorber also allows the system to be installed to various lightweight modern roof constructions. Unlike other systems, there is no need for expensive 'fall over' posts at every support, instead **KEELINE** features unique 'see through' top mount posts with minimal roof penetration required. **KEELINE** for structures is available for mounting directly to concrete, steel, brick or stonework either in the horizontal or overhead application. To ensure simple specification **KEELINE** installations can be designed using our proprietary calculation software. **KEELINE** is also available for use with the **WIREANKA** product line of deadweight anchors when there is a preference not to penetrate the roof at all, for permanent or temporary applications. **KEELINE** conforms to ANSI/ASSE Z359.1 2007, OSHA 1915.159, 1926.502M, CAN/CSA Z259, EN795 Class C and AS/NZ S 1891.2 and is CE marked.

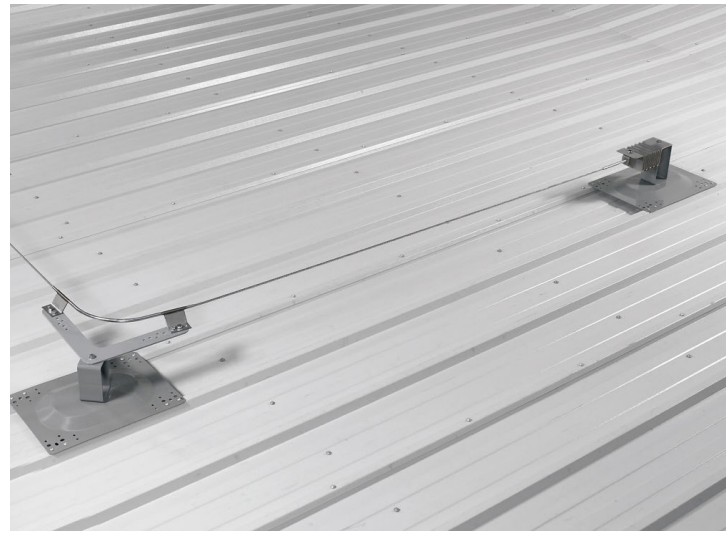

KEE LINE for ROOFS

Outline Roof Plan

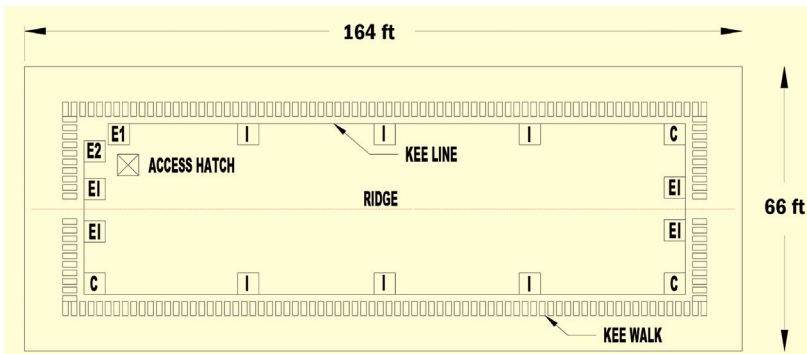

E1 - Extremity Assembly (start of system)



E2 - Extremity Assembly (end of system)



I - Intermediate Assembly



C - Corner Assembly (90° or 135° options)



EI - Extended Intermediate Assembly

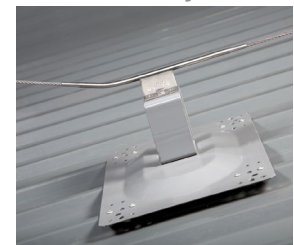

KEELINE has two base plate options to ensure easier specification and to minimize stock holding. The range of base plates have been designed to suit end, corner and intermediate brackets.

The **MR base plates** are for metal profiled and standing seam roofs.

The **FR base plates** for membrane roofs incorporates recessed holes for fixings to allow waterproofing membrane to sit flat on top of the base plate.

KEELINE for STRUCTURES

KEELINE for structures is accomplished with brackets that fix directly to steel, concrete, brick or stonework. This system is suitable for horizontal or overhead applications.

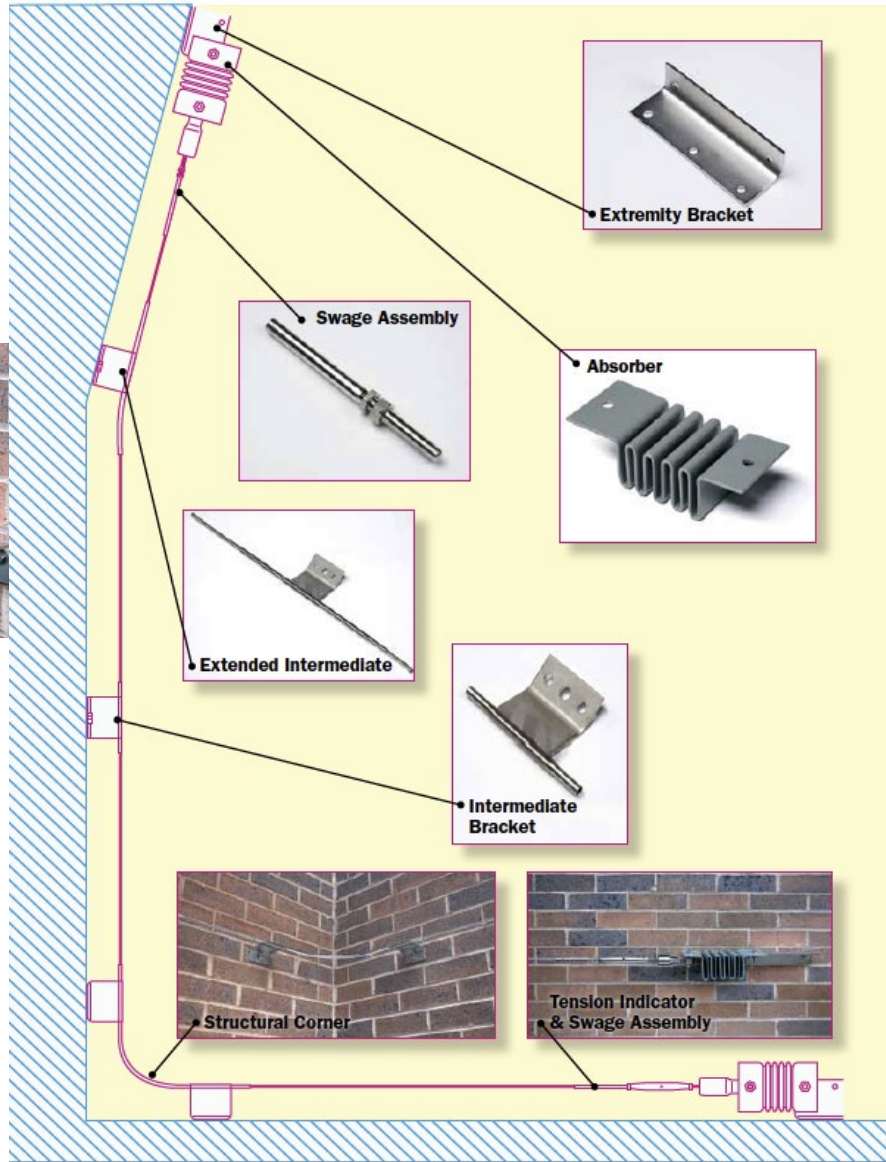

KeeLine Traveller

- Allows user to attach at any point on system
- No moving parts
- Passes corners and intermediates without needing to detach from the system
- Durable and weather resistant
- Made of cast 316 stainless steel



Features

- Conforms to ANSI Z359, CSA Z259, EN795 Class C and AS/NZS 1821
- CE Approved to the PPE Guidelines
- Provides users with total fall protection with continuous attachment while travelling the system
- Efficient heavy duty in-line absorber negates the need for expensive 'fall over' style posts at every bracket position
- Maximum span in between supports is 50 feet
- Accommodates corners and varying building shapes
- Grade 316 Stainless Steel 5/16 inch diameter wire and bracket
- The design and specification process is simplified by the custom calculation software
- Open style, low profile top mount posts to suit modern roof constructions including metal profile, standing seam and membrane roofs
- Comprehensive range of mounting options
- Traveller enables users to detach or re-attach at any point of the system
- Allows for multiple users
- Modular design for easier specification and simple installation
- Provides users with total fall protection through continuous attachment whilst travelling the system
- Adaptable to different usage situations
- Durable and weather resistant

Kee® Anchor



portable deadweight anchor systems for area specific and entire rooftop coverage of personal protection

KEE®ANCHOR fall restraint systems are designed for use where installation of passive fall protection systems or permanent anchor devices is not viable or desired. There are two different non-penetrating portable deadweight anchor systems.

The **WEIGHTANKA** system is designed for use in one specific designated area, while the **WIREANKA** system utilizes a horizontal line allowing workers to cover a larger span of the rooftop. An entire base system weighs only 550 pounds, and no individual component weighs more than 55 pounds, making the **KEE ANCHOR** fall restraint systems practical for portable use.

Anchor Kart

Anchor Kart is designed to hold up to 4 units for easy transportation on the roof top or in the plant. The pneumatic wheels make pulling the weight easier. These wheels also spread the overall load evenly. The unit features two large locking tool boxes for safe job site storage of PPE and other valuable tools. Designed to fit into pickup trucks for cross town or to job site movement. A perfect compliment to the mobility of the Wireanka system.



Weightanka non-penetrating mobile
deadweight anchor system

A KEE SAFETY PRODUCT

Deadweight Anchor System

WEIGHTANKA is a mobile, deadweight anchor system for use on roofs up to 5 degree pitch. The quick-to-assemble system features a central pedestal attachment point which raises the height where the arrest force is applied.

With the correctly specified model the system can be used on any of the following roof surfaces in WET or DRY conditions:

- Single Ply Membrane
- Mineral Felt
- Stone Chippings (Brushed)
- Concrete
- Asphalt

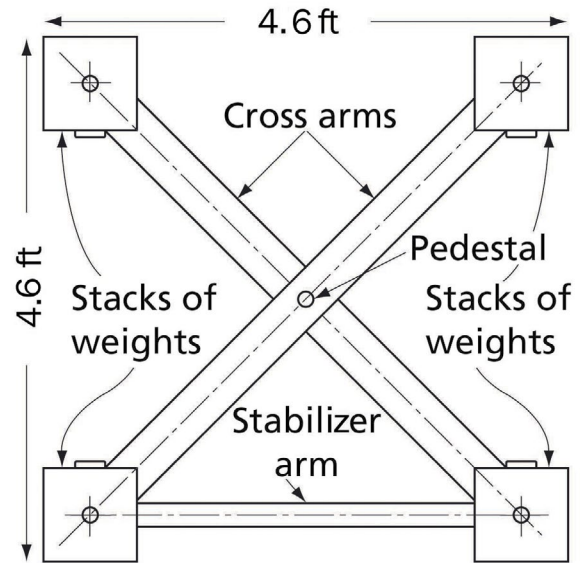

Features and Benefits

- Fall restraint for up to 2 workers providing they cannot get to less than 20 inches from the edge
- Rubber molded base weights prevent rubber pads 'peeling' at the edges
- Over 100 suction cups molded into each rubber bonded weight to maximize grip
- Galvanized to BS EN ISO 1461
- Does not penetrate roof surface
- Raised central pedestal reduces the distance of travel during the event of a fall arrest
- Easy to assemble, minimal amount of components and no need for extra tools
- Conforms to CLASS E EN 795, BS 7883 & ISSO 14567



Protective cover available for installations that remain assembled in position year round. The cover is 58" Blue PVC with 4" skirt elastic.



WIREANKA

Wireanka

anchor device system to support horizontal flexible safety line

A KEE SAFETY PRODUCT

Deadweight Anchor System for Flexible Safety Line

WIREANKA is a system of deadweight anchor devices that supports flexible safety line at each anchor. It is intended for use on flat roofs, in temporary situations, or where it is preferable that penetration of the roof surface be avoided and a larger area of the roof needs fall protection.

With the correctly specified model the system can be used on any of the following roof surfaces in WET or DRY conditions:

- Single Ply Membrane
- Mineral Felt
- Stone Chippings (Brushed)
- Asphalt
- Concrete



Permitted Number of Users

For fall arrest purposes no more than one user may be attached to the system at any one time. For restraint purposes only up to two users may be attached at any one time. For users to be classified as “restraint”, the combination of the WIREANKA position and the use of the fixed length lanyards must ensure that it is not possible for them to approach within 20 inches of a roof edge or other opening. Special configurations (at an extra cost) allow for additional users.

* For minimum edge distance and minimum free fall distance please contact Kee Safety's technical department.

Features and Benefits

- Rubber molded weights prevent rubber pads peeling at edges
- Does not penetrate roof surface
- Suitable for use on any premises where disruption of day-to-day running by opening the roof is to be avoided
- Galvanized to BS EN ISO 1461
- Base weights fully encased in rubber molding

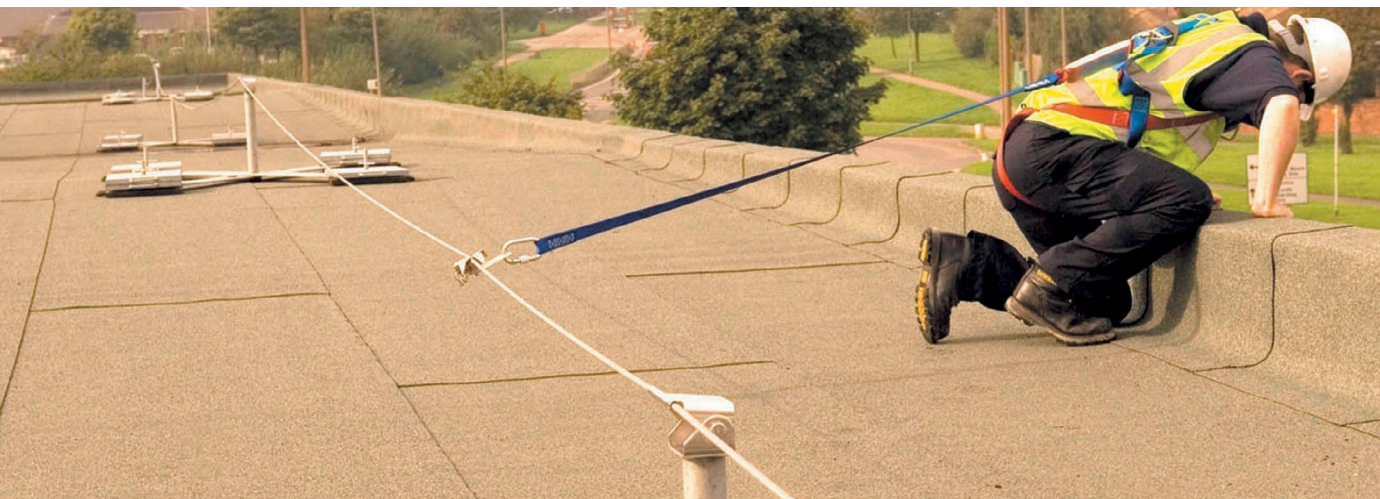
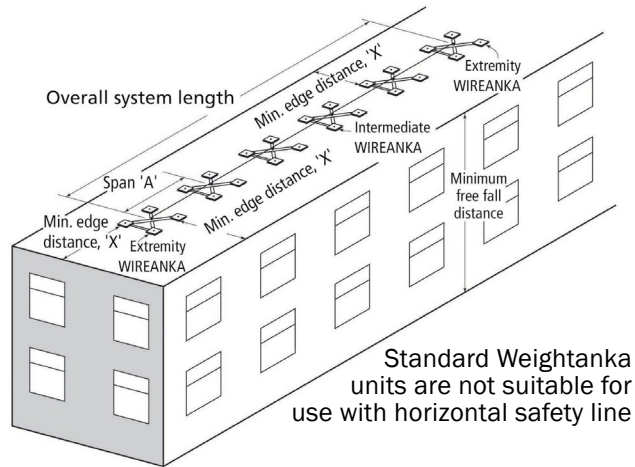



a modular easy to install walkway system designed to the requirements of EN 516:2006 providing a safe, anti-slip, level surface

KEE WALK provides a safe, anti-slip, level walking surface for anyone who needs to access a roof in the course of their work. It provides a clear demarcation route which protects the roof from unnecessary damage and uniformly distributes the pedestrian load across the surface.

This system will cater to flat, barrel and sloping roofs, with steps and a traverse option allowing for access to be created for virtually any roof configuration from 0 to 35 degrees.

KEE WALK is a modular system complying with the test requirements of EN 516:2006 (Prefabricated Accessories for Roofing - Installations for roof access - Walkways, Treads and Steps).

Easy assembly utilizing standard components removes the need to have parts specifically manufactured off-site, making installation and specification quick and simple.

KEE WALK is designed for modern roof types including trapezoidal profile composite or built up and standing seam metal roofs.

The **KEE WALK** system is fully compatible with all horizontal safety line systems including Kee Safety's Kee®Line system.

Features

- Provides a safe, level walkway across a roof surface
- Designed for use on composite, trapezoidal metal profile and standing seam roofs
- Flexible, modular system adaptable to changing roof angles from 0 to 35 degrees
- Fully adjustable on site
- Lightweight aluminium bearer bars for all roof types
- Minimal selection of brackets required to install system
- Fire rated to class HB of UL94 (harmonized with ISO 9772)
- Nylon treads with enhanced slip resistance for adverse weather conditions
- Open tread ensures water drains away easily
- 5' and 10' pre-assembled lengths supplied as standard from stock
- Treads and bearer bars are recyclable
- Fixings do not damage the integrity of the roof surface
- Contrasts with roof surface to provide a clear demarcation route

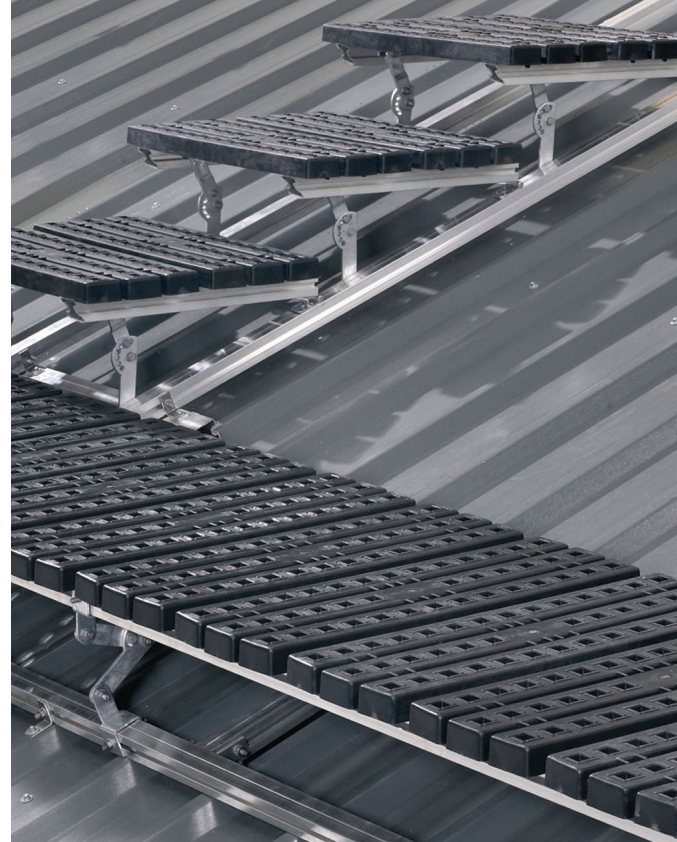



High Grade Nylon Tread

Manufactured in a high grade nylon incorporating raised roughened sections. The treads are developed to comply with EN 516 (Prefabricated Accessories for Roofing - Installations for roof access - Walkways, treads and steps), exceeding the deflection criteria and slip resistance requirements of the standard.

The treads, when supplied separately to build steps or walkway sections less than the standard pre-assembled sections, are quickly secured onto the aluminium bearer bars using two self drilling screws,

fixed in the center holes. Additional fixing holes are provided on either side of the center holes. Their design incorporates spacers to ensure simple, correct spacing and alignment. A tread measures at 8-5/8" wide and 24-3/8" long. Sections can be cut down if required to fit between points.

Description	Degrees	Length in feet
Walkways Traverse Configuration	0 - 5	10 ft
Walkways Traverse Configuration	0 - 5	5 ft
Walkways Traverse Configuration	5 - 7.5	10 ft
Walkways Traverse Configuration	5 - 7.5	5 ft
Walkways Traverse Configuration	7.5 - 12	10 ft
Walkways Traverse Configuration	7.5 - 12	5 ft
Walkways Traverse Configuration	15 - 35	10 ft
Walkways Traverse Configuration	15 - 35	5 ft
Walkways Configuration	0 - 5	10 ft
Walkways Configuration	0 - 5	5 ft

Description	Degrees	Length in feet
Step Configuration	5 - 10	10 ft
Step Configuration	5 - 10	3.5 ft
Step Configuration	10 - 15	10 ft
Step Configuration	10 - 15	5 ft
Step Configuration	15 - 25	10 ft
Step Configuration	15 - 25	5 ft
Step Configuration	25 - 35	10 ft
Step Configuration	25 - 35	4.5 ft

Description	Degrees	Length in feet
Traverse (Raised)	0 - 5	10 ft
Traverse (Raised)	0 - 5	5 ft

Description	MPH	Length in feet
Free Standing Module - Standard	75 mph	10 ft
Free Standing Module - Standard	75 mph	5 ft
Free Standing Module - Premium	90 mph	10 ft
Free Standing Module - Premium	90 mph	5 ft

Traverse Configuration

Keek Walk is designed to make the task of building a walkway across a sloping roof a simplistic installation, using a standard set of components. A traverse section of walkway uses a standard Keek Walk section for the level walking surface which is mounted onto a sub-frame fixed to the roof. The two sections are joined with hinged brackets at the rear of the assembly and use the rotating arms at the front to level the walking surface.

Longitudinal 10ft Configuration

Supplied pre-assembled to facilitate rapid on-site installation which will minimize installation costs. The standard lengths have 12 treads per 10 feet. Weighing only 105 lbs the standard lengths are easily positioned and aligned. They are joined together by a simple 4 inch long straight connector which attaches to the bearer bars.

Free Standing Configuration

Free standing modules can only be used when the angle of the roof surface is less than 5 degrees inclined. These modules are held in place with the KeeGuard 100% recycled PVC counterbalances and do not penetrate the roof surface. Each weighs 30 lbs and are 18" x 20" x 3".

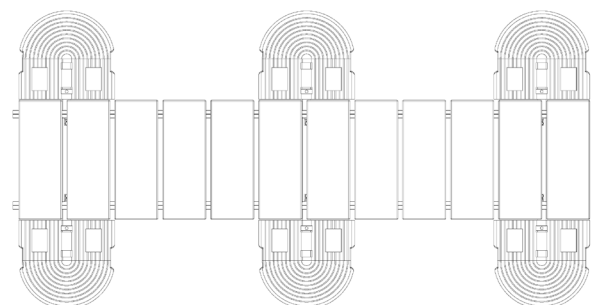

options

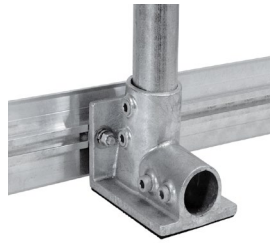

Toeboards

Our unique design does not require any drilling on site or in the shop. A slot on the back of the toeboard accepts a bolt head which prevents the bolt from spinning during assembly. Upright hardware and splice kits for corners and straight sections are also available. Toeboard comes in 24' lengths or can be custom cut.

Parapet Component

A new component designed to retrofit roof parapets that are not compliant with OSHA standards. Rail anchor is angled inward so as not to detract from the aesthetics of your building. KEE KLAMP Type 316.

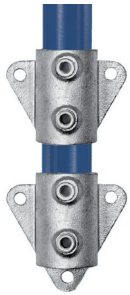

Exterior Wall Mount

Two KEE KLAMP Type 68 components or other methods can be employed to attach rail directly to an outer wall. This method is used when equipment or other impediments block the roof edge, not allowing room for our free standing KEEGUARD counterbalance system.



Safety Gate

An additional safety feature to your KEE HATCH or KEEGUARD system. Our safety gate has spring hinges and 180° rotation. Installs with simple hand tools to existing uprights.



Grip Tape

Improves grip of existing handrail. Grip Tape has a glow-in-the-dark feature for added safety. Yellow and black coloring is also available.

RAL Color

To enhance visible safety as well as integrate with building aesthetics, KEEGUARD components can be powder coated to match any RAL color.



Hi-Traction Covers

Improve footing and help prevent slips and falls. Suitable for indoor and outdoor use. Variety of grip options, colors, sizes, and materials. Glow-in-the-dark and custom printing available.

S-5! Clip

Mount quickly and securely with S-5! penetration-free attachment that lasts as long as the roof, itself



custom applications





USA

Kee Safety, Inc.
100 Stradtman Street
Buffalo, NY 14206

Tel: (716) 896 4949
Fax: (716) 896 5696
Toll Free: (800) 851 5181

www.keesafety.com
Email: info@keesafety.com

Canada

Kee Safety, Ltd.
219 Connie Crescent, Unit 9
Concord, Ontario L4K 1L4

Tel: (905) 669 1494
Fax: (905) 669 4347
Toll Free: (877) 505 5003

Kee Klamp, Kee Lite, Kee Stainless, KeeGuard, Kee Dome, Kee Hatch, Kee Mark, Kee Access, KwikKit, Kee Anchor, Weightanka, Wireanka, Kee Line, Kee Walk and Kee Projects are all registered trademarks of Kee Safety Ltd, Beam Clamp, and Box Bolt are all registered trademarks of Access Technologies Ltd, a subsidiary of Kee Safety International Ltd. While every effort has been made to ensure the accuracy of the information contained in this brochure, Kee Safety, Inc cannot be held responsible for any errors or omissions. Kee Safety, Inc reserves the right to alter or withdraw products without prior notice. Kee Safety, Inc does not accept responsibility for any loss or damage arising from improper use of its products.

Copyright 2011 Kee Safety, Inc. All Rights Reserved.