



ABB low voltage drives

# ABB HVAC Packaged Drives E-Cclipse Bypass

# Introducing the ABB E-Clipse Bypass

In 1999, ABB introduced the world's first E-bypass design. Today, ABB has over 100,000 successful E-bypass installations world-wide. The initial focus in developing the E-bypass design concentrated on thoroughly understanding overall market, application and customer requirements where the E-bypass would be used. This focus was crucial to the resulting overall E-bypass design strategy and approach.

As a result of this effort, the determination was made that the only way to meet the demands of the current and future market and customer requirements was to implement a full digital microprocessor-based control in the E-bypass. The ABB E-Clipse Bypass has taken these developments to the next level. In addition to the benefits of the previous ABB design, ABB has added new capabilities focused upon the changing and evolving customer and market requirements. This brochure will give the user a brief overview of these features and benefits.



## A Temperature Control Contractor Says...

- Having BACnet, FLN, ModBus, and N2 on board as standard means no additional cost or option modules for most communications projects.
- Serial communications directly to the bypass means no failed point on my network even if the VFD is out for maintenance or service.
- Onboard proof-of-flow indication and action means I no longer have to purchase expensive, prone to fail current transformers and relays.

## Specifying Engineers State...

- The built-in communications suite means that I can have intelligent drive and bypass applications regardless of which temperature control contractor is successful on the project.
- ABB has thoroughly researched smoke control applications and embedded the correct response to all smoke emergency situations into this unit. UL type enclosures and seismic certification means I can apply the ABB E-Clipse Bypass in almost any application.
- With the VFD's 5% swinging choke and the VFD and bypass' RFI / EMI immunity, plus the regulated power supply (which means no issues during my monthly generator tests), the ABB E-Clipse Bypass is the only bypass I consider specifying in sensitive applications such as hospitals, airports, and laboratories.



## Feedback from Facility Managers...

- Seismic certification is important to me. I wish all of my electrical equipment was seismic tested and certified.
- Individual safety annunciation means no more chasing down which interlock has opened.
- The supervisory controller means my cooling tower or pumping application is still functioning even if the VFD isn't.

## A Contractors Point of View...

- The ABB E-Clipse Bypass is bullet proof. It even tells me in plain English if I have mis-wired the application and the fan is going to spin in reverse.
- The intelligent bypass and keypad diagnostics makes start up a snap. The bypass status LEDs and keypad messages let me know instantly if I have a VFD, a bypass, or an external issue.
- Individual safety annunciations makes troubleshooting start up issues a breeze.



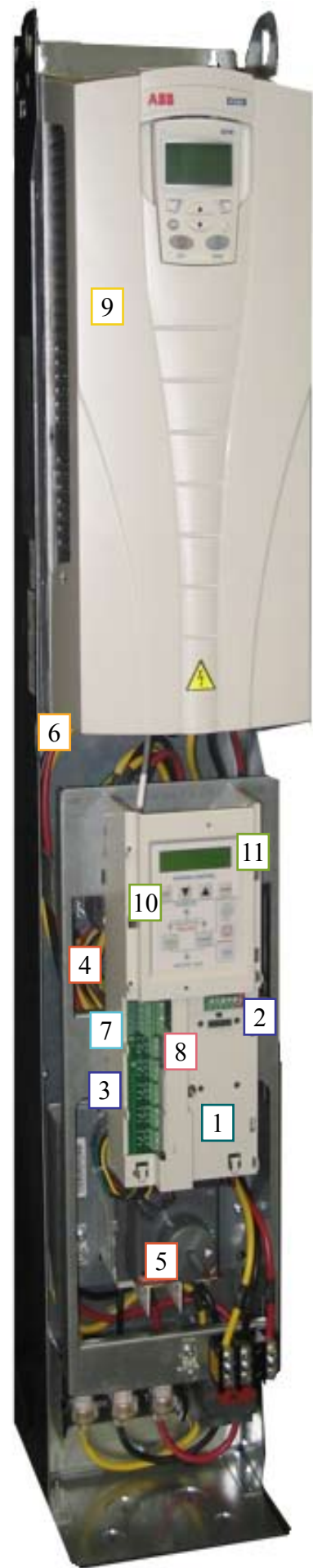

### 2 Bypass Serial Communications

- + BACnet, FLN, ModBus, and N2 protocols on board
- + First in Industry
- + Over 45 points of bypass data/control
- + Go to bypass mode with no failed point on the communication network
- + Serially monitor amps, kWhrs, operating mode, and more – even in bypass mode

### 3 Pass Through I / O

- + Command 5 bypass relay outputs
- + Monitor and display which safety interlock is open
- + Control external devices (such as dampers and valves) via serial communications
- + 24 free I/O points - counting VFD

### 4 Regulated Power Supply

- No contactor chatter
- Tolerates +30, -35% voltage fluctuations
- + Welded contactor indication and action
- + Open contactor protection with diagnostics
- + Uses 115Vac contactor coils

### 5 Single Phase Protection

- Single phase motor protection - VFD and bypass
- No need for expensive add-on voltage monitors, circuits and relays
- + Included in every ABB E-Clipse Bypass

### 1 Intelligent - Microprocessor Based Advanced Features

- Microprocessor receives and processes all inputs for advanced features such as damper control/proof and smoke control
- + Supervisory control of pumps and cooling towers
- UL Listed motor Overload protection
- Most of the other advanced features called out on this page

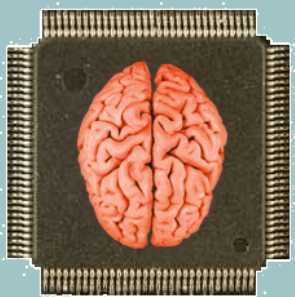

### 6 Seismic Qualification Certificate

- + Tested to ICC-ES AC156
- + Designated Seismic System
- + Works even after seismic event

### 7 Proof-of-Flow (Broken-belt) Annunciation and Action

- Programmable proof-of-flow trigger
- + Proof-of-Flow indication on keypad
- Proof-of-Flow in both VFD and bypass modes
- No need for expensive, failure prone programmable current transmitters/relays

### 8 Smoke Control

- Two available overrides
- + Non programmable Smoke Control override designed to comply with UL864/UUKL
- + Second override may be field programmed to meet local AHJ
- + Becomes an integral part of your smoke control system

### 9 Stand Alone Operation

- + Serial communications still active, even with VFD removed
- Full bypass control without VFD
- + Supervisory control of application in bypass mode
- + Monitor all digital inputs and monitor and command all relay outputs
- + Monitor Volts, Amps, kWhrs and much more - even in bypass mode

### 10 Advanced Plain-English Bypass Keypad

- System status LEDs
- + Superior system diagnostics
- + Advanced system programming
- + Sophisticated yet simple user interface

### 11 Individual Safety Annunciation

- + Up to 4 individual safeties
- + Unique name for each
- + Plain English display
- Safety annunciation over serial communicators



| Safety          |                   |
|-----------------|-------------------|
|                 | FireStat          |
|                 | FirezoneStat      |
|                 | Smoke Alarm       |
|                 | Vibration Trip    |
|                 | Over Pressure     |
|                 | Low Suction       |
| Run Permissions |                   |
|                 | Damper End Switch |
|                 | Valve Opening     |
|                 | Pre-Lube Cycle    |









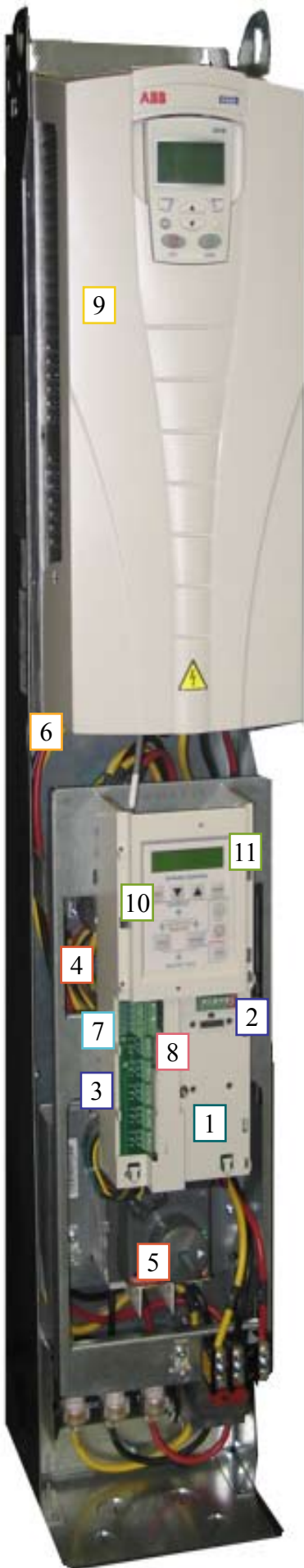







# Applications



- Important
- • Critical



| ABB E-Clipse Bypass Feature:   | <br>Hospitals | <br>Universities K-12 | <br>Airports & Labs |
|--|---|--|--|
| <b>1</b> Intelligent - Microprocessor Based Advanced Features<br> | •   | •  | •  |
| <b>2</b> Serial Communications<br>                                | •   | ••   | •  |
| <b>3</b> Run Permissive Damper Control & Proof<br>                | •   | •  | •  |
| <b>4</b> Regulated Power Supply<br>                             | ••  | ••   | ••   |
| No Contactor Chatter   | ••  | •  | •  |
| <b>5</b> Single Phase Motor Protection<br>                      | •   | •  | •  |
| <b>6</b> Seismic Certification<br>                              | ••  |  | ••   |
| <b>7</b> Proof-of-flow (Broken-belt)<br>                        | •   | •  | ••   |
| <b>8</b> Advanced Smoke Control<br>                             | ••  | ••   | ••   |
| <b>9</b> Stand Alone Operation<br>                              | ••  | •  | ••   |
| <b>10</b> Advanced Keypad Status & Diagnostics<br>              | •   | ••   | •  |
| <b>11</b> Individual Safety Annunciations<br>                   | •   | •  | ••   |

## Intelligent Microprocessor Based Advanced Features

In 1999, ABB introduced the world's first E-bypass design. Today, ABB has over 100,000 successful E-bypass installations worldwide. The initial focus in developing the E-bypass design was to thoroughly understand the overall market, applications, and customer requirements where the E-bypass would be used. This focus was key to ABB's overall design strategy and approach.

As a result of this effort, the determination was made that the only way to meet the requirements of the current market, future market and customer demands was to implement a full microprocessor-based control in the E-bypass. The ABB E-Clipse Bypass has taken these developments to the next level. The ABB E-Clipse Bypass incorporates all of the features and functions you have come to know and love and added new capabilities focused on our changing and evolving market and application requirements.

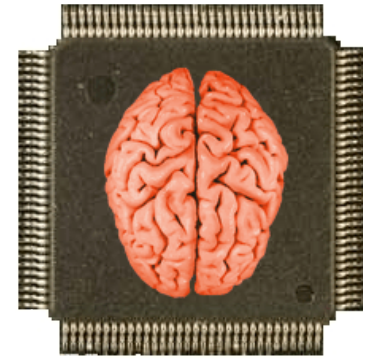

The intelligence of the ABB E-Clipse Bypass is what differentiates this product from competitive offerings. The ABB E-Clipse Bypass microprocessor receives and processes all inputs into the system. These inputs may be digital inputs from customer supplied contact closures, serial communication inputs from the various Building Automation System (BAS) protocols, maintained contact closure inputs from devices such as safeties and damper proofs, or contacts from other sources such as the fire / smoke control panel (FSCP).

The ABB E-Clipse Bypass is structured around this intelligent microprocessor-based control. Microprocessor-based control is what allows ABB to provide the bullet proof contactor control and protection, serial communications, single phase control and protection, built-in broken-belt indication, and advanced smoke control action.

All of this intelligence is then linked to the advanced plain English bypass keypad for a superior human-machine interface. The ABB E-Clipse Bypass does not simply accept contact inputs from the customer and take the appropriate actions; the microprocessor-based intelligence in the ABB E-Clipse Bypass also allows for intelligent control of your application.

For example, by monitoring individual phase current, using built-in current transformers, ABB can obtain single phase protection of the A/C motor in the bypass mode without the need for additional current transformers, potential transformers, and external voltage monitoring circuit hardware. The microprocessor also provides the UL-listed motor overload protection, without the need for bimetallic overload heaters and relays.

The microprocessor-based control has allowed ABB to implement a supervisory control mode into the ABB E-Clipse Bypass. In the supervisory control mode, the bypass monitors the 4-20 milliamp process feedback level coming to the variable frequency drive. The feedback level is then used to activate and deactivate the bypass contactor. This "bang-bang" control allows the user to maintain hysteresis control over applications such as cooling towers and booster pumps, even with the VFD out of service.

In addition, the microprocessor handles the brunt of the computational requirements for the run permissive circuit (damper actuator and proof receipt), the two different types of Fireman's override, and the multiple safeties and individual safety annunciation.

ABB chose to put a microprocessor into a new bypass controller in 1999. In 2008, the ABB E-Clipse Bypass takes the success of over 100,000 units installed to new heights.

[Return to Brochure](#)

## Bypass Serial Communications

All ABB E-Clipse Bypass systems include the most common HVAC protocols as standard features. Included in every bypass shipped are ModBus, Johnson Controls N2, Siemens FLN, and BACnet communications protocols. Other protocols such as Lon Works, Profibus, Ethernet and DeviceNet are available as plug-in option cards.

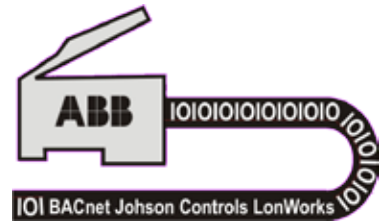

In 1994, ABB pioneered serial communications for VFDs in the HVAC industry. Today ABB has installed over 150,000 units (in the U.S. alone) connected to building automations systems using the various HVAC communications protocols.

The ABB E-Clipse Bypass includes serial communications in the bypass mode. Now, going to bypass does not mean losing control!

In all previous designs, switching to bypass mode meant the VFD displayed as a failed point on the building automation system network. With the ABB E-Clipse Bypass, serial communications to the bypass controller means no loss of communication or control, and no failed point on the BAS network. The VFD may even be removed from the system (and sent back to the factory for repair, for example) with no loss of communications or control. The BAS system can still start and stop the application; monitor amps, volts, and kilowatts hours (and other objects); and monitor all warning and fault annunciations.

Over 45 individual points of data are communicated between the bypass and the BAS system master controller. For example, the operator can monitor all safeties, damper end-switch proofs, and any other digital inputs to the system. In addition, the operator can start and stop the bypass over serial communications or force the system into override mode.

Proof-of-flow, over temperature conditions, or other system warnings may also be displayed on the BAS master controller. Finally, all faults can be displayed at the master controller along with remote system fault reset capability via serial communications.



BACnet is a registered trademark of ASHRAE. ASHRAE does not endorse, approve or test products for compliance with ASHRAE standards. Compliance of listed products to requirements of ASHRAE Standard 135 is the responsibility of the BACnet Manufacturers Association (BMA). BTL is a registered trademark of the BMA.

[Return to Brochure](#)

## Pass-through I/O

In 1997, ABB pioneered serial communications pass through I/O with the release of the ACH400 series drive. Pass-through I/O means the user can monitor all digital inputs on the variable frequency drive, and control all relay outputs and analog outputs on the variable frequency drive over the communications connection. This pass through I/O was quickly adopted by the more progressive temperature control contractors as a method of reducing system installed costs. For example, the BAS integrator could now use the VFD relay outputs to start a lag pump drive, open an isolation damper, or control any auxiliary device that requires a maintained contact closure for operation. In addition, all digital inputs such as damper receipt proof contacts, safeties, or supply fan run interlocks to the return fan can be monitored over the building automation system through the VFDs I/O.

However, using the VFD's I/O for control of the system inherently meant that, if the VFD was in a non-operational state, any ancillary devices that were being controlled through the VFD's I/O were also non-operational. The ABB E-Clipse Bypass addresses these concerns. With the ABB E-Clipse Bypass, I/O remains available to the BAS system even with the VFD removed. The BAS system integrator/end user now has complete confidence that, even if the drive were to fail, any ancillary devices being monitored and/or controlled using the system I/O available still is functional - even in the bypass mode.

The possibilities are limitless with this capability. If one counts the VFD and bypass I/O, the ABB E-Clipse Bypass and ACH550 drive gives the temperature control contractor a total of 24 free I/O points for their use, in addition to two free PID loops.

The ABB E-Clipse Bypass takes the serial communications functionality originally pioneered in 1997 to a whole new level!

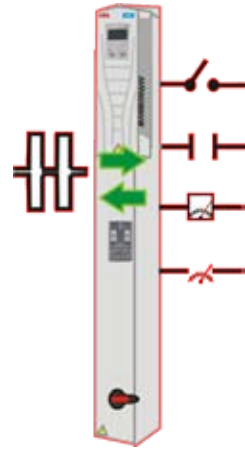

[Return to Brochure](#)

## Regulated Power Supply = Wide Voltage Tolerance

By far the most commonly reported problem with the classic (non-electronic) style of bypass was contactor coil failure caused by low-line or single phase input conditions.



Modern AC drives have a very wide voltage tolerance range. However, standard low voltage controls (contactors) typically are rated for approximately -15% nominal voltage maximum. A common problem with classic style bypasses was contactor chatter due to low line conditions followed quickly by contactor coil failure.

The typical scenario - a utility has a fault on one of their systems. This fault often is caused by a lightning storm, a downed power line due to a fallen tree, a car accident, an ice storm, or a rodent / bird problem.

While the utility is clearing their fault or re-routing power, a classic bypass may be subjected to a brownout condition. For example, a 480V drive/bypass now is receiving 350V or less. The 480:115V control power transformer in the classic bypass will have an output of about 85V instead of the nominal 115V. The drive output contactor drops out at about 100V. However, the building automation system is still sending the "run" contact to the drive/bypass system, so the contactor attempts to re-close.

However, the contactor is not being supplied enough voltage to pull in and seal in, so it bounces (chatters). The contactor coil also is pulling higher than normal amps because of the low voltage condition and the increased in-rush current caused by the pull-in effort. This cycle repeats until the contactor coil overheats and fails.

A stand-alone ABB VFD, without a classic bypass would have no issue with this brownout condition (unless the VFD was at full-load / full-speed during the brown-out event). The VFD is capable of input single phase operation and is generating a balanced three phase output to the motor. The fan or pump would continue operating without missing a beat if there were no bypass present!

Why did the customer pay the extra money for a bypass in the first place? Typically, this is because the customer felt that the driven fan or pump is on a critical application that cannot be without flow. In this situation, using as an example a 5 HP application, the customer had doubled the first cost of the drive (by adding a classic bypass) and inadvertently made the application less robust!

When ABB pioneered the electronic bypass in 1999, contactor chatter and failure was one of the problems with traditional bypass designs that ABB was determined to solve. The ABB E-Clipse Bypass has a regulated power supply circuit that keeps standard, ABB off-the-shelf 115V coil contactors seated and operating properly at guaranteed nominal voltage of +30% -35% (at minimum). This voltage tolerance range is maintained over all input voltage classes; 208, 240, 480, and 600V ABB E-Clipse Bypass units.

In addition, the micro processor based "brains" in the bypass protects the system from welded contacts and contactor failure to close. A coil monitoring circuit checks if the bypass or drive isolation contactor coil is not seated when the control system is commanding same closed. The system will trip off line and annunciate the "open contactor" condition if the contactor is not in the commanded state.

Finally, the bypass micro processor monitors if a contactor is closed when it should not be and will fault and display a "Bypass Contactor Stuck" or "Drive Contactor Stuck" annunciation on the keypad. This condition may be linked to a relay output. The relay output may then be used to trip an up-stream, shunt-trip circuit breaker to take the unit off-line. This feature allows one to protect the motor if the bypass contactor contacts become welded.

Motor protection, no contactor coil failure, drive operation in a single phase input situation, and contactor monitoring, all add up to a bullet proof, intelligent bypass system - the ABB E-Clipse Bypass.

[Return to Brochure](#)



## Single Phase Protection

The microprocessor-based design allows for many standard features in the ABB E-Clipse Bypass. For example, by monitoring output phase current using built-in current transducers, and feeding this information to the microprocessor-based controller - the ABB E-Clipse Bypass is capable of detecting and protecting the motor from input single phase conditions when in the bypass mode. Without a microprocessor-based design, this would require potential transformers and current transformers along with voltage monitoring hardware and relays to obtain single phase protection. The microprocessor-based design allows this single phase protection to be built-in as standard.



The ABB E-Clipse Bypass also monitors all three input phase voltages to the system. The ABB E-Clipse Bypass will allow the system to continue running if the system is in drive mode and a input single phase is present, but will trip off-line if the system is in the bypass mode when the single phase condition occurs, protecting the motor. In addition, the microprocessor uses the measured and calculated output current to provide the UL-listed motor overload protection.

[Return to Brochure](#)

## Seismic Qualification Certificate

All ABB E-Clipse Bypass units comply to Section 1615 of the International Building Code, 2006 edition. Representative units were tested to test protocol AC156. These units were tested with an equipment importance factor of 1.5. An equipment importance factor of 1.5 indicates that the equipment functionality was verified before and after seismic simulation testing. This importance factor is indicative of critical facilities where maximizing the probability of post-event functionality is a priority. In other words, the ABB E-Clipse Bypass has been tested to function, even after an earthquake



ABB chose to test the ACH550 drive and E-Clipse Bypass to the importance factor of 1.5 because these drives and bypasses often are applied in critical applications such as hospitals, airports, and other facilities where lives are at stake.

The ABB ACH550 drive and ABB E-Clipse Bypass seismic withstand capacity was determined from seismic shake table test results defined in the International Code Counsel's (ICC) Acceptance Criteria for Seismic Qualification Testing of Non-structural Components (AC156). The Building Seismic Safety Council (BSSC) recognizes AC156 as an appropriate shake testing protocol. The National Institute of Building Sciences established the BSSC in 1979 to develop and promote regulatory provisions for earthquake risk management at the national level. The National Earthquake Hazard Reduction Program (NEHRP Provisions 6.4) also references AC156 as a national standard, and as a preferred shake-table testing protocol, which meets the force requirements of the Provisions and the American Society of Civil Engineers (ASCE 7-02).

ABB is pleased to certify that ABB ACH550 drives and the ABB E-Clipse Bypass series comply with National Seismic Qualification requirements.

[Return to Brochure](#)

## Proof-of-Flow Annunciation

Proof-of-flow annunciation / broken-belt indication is now easier than ever. Since 1995 ABB has been able to provide drive proof-of-flow indication over your serial communications connection. The ABB E-Clipse Bypass technology extends this feature to units with both VFDs and bypasses.



The ABB E-Clipse Bypass system allows unprecedented diagnostics and fault annunciation through the onboard keypad and/or via serial communications. ABB's first E-bypass, released in 1999, included a programmable broken-belt fault only. The ABB E-Clipse Bypass includes programmable broken-belt indication levels, selectable warning or fault, and annunciation of both via the bypass keypad and over serial communications.

Also, the temperature control contractor or end user no longer needs to source and install expensive, PWM waveform compatible, current-sensing relays for proof-of flow. This hardware often was installed in the motor control center feeding the VFD / bypass and took up valuable real estate. These special current sensing relays often are less than robust in design and require an additional monitoring point on the BAS system.

With the ABB E-Clipse Bypass, all of the above expense and wasted real estate is avoided. In addition, the bypass is one node (address) on the BAS system with proof-of-flow indication as one of the 45 + objects included in the one bypass node.

### As Simple as 1-2-3

Using the broken-belt feature on the ABB E-Clipse Bypass is a very simple process. First, select the type of response you would like the system to have under a loss-of-load condition. Next, program the percent of motor full load trigger level for proof-of-flow. Finally, determine whether you wish this information to simply display on the bypass keypad, or also to be annunciated over serial communications and / or via relay output.

The user can choose a common output for a system broken-belt indication, or broken-belt indication in drive mode with a separate indicator for broken-belt in the bypass mode. Other system (drive or bypass) level indicators are available such as system running, system overload, and system fault.

[Return to Brochure](#)

## Smoke Control

Smoke Control operation for supply fans and return fans requires the system to ignore some external inputs, while acknowledging other system inputs. For example, for proper operation, a return/exhaust fan should ignore a return duct smoke detector input but should acknowledge a supply fan smoke detector input. The ABB E-Clipse Bypass is designed to meet the intent of the UL864/UUKL specifications.



The Smoke Control override input in the ABB E-Clipse Bypass is always wired into Digital Input 6 on the bypass. The Smoke Control override always functions as shown on the wiring diagram below.

### Typical Wiring Diagrams Showing a Conventional VFD/Bypass Wiring and Use of the E-Clipse Bypass

Typical wiring with use of E-Clipse Bypass:

#### E-Clipse Bypass Controller Input

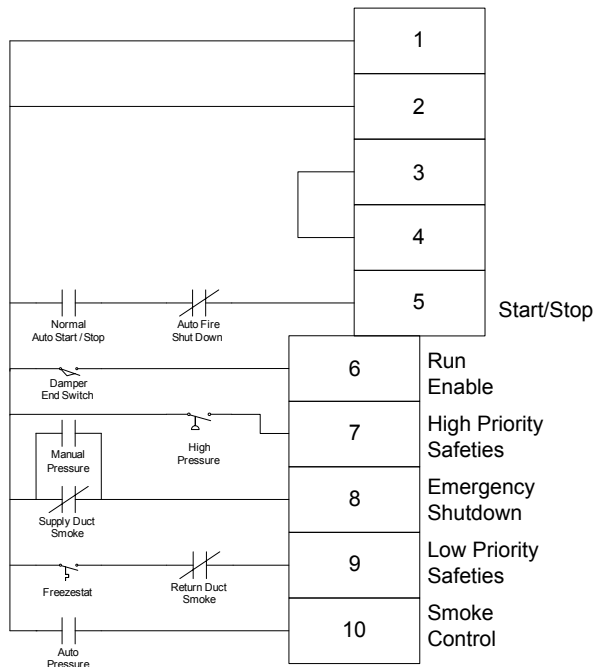

Normal Operation:

- Close Start/Stop (DI-5)
- Fan starts assuming that DI-6, 7, 8, and 9 are all closed

Emergency Shutdown:

- Open fire shutdown, unit stops

Smoke Control Mode:

- Close contact on DI-10
- Fan starts regardless of position of internal HOA switch and inputs DI-5 and DI-9
- Inputs DI-6, 7 and 8 followed
- Internal overloads followed

Typical starter wiring for a UUKL listed System Today:

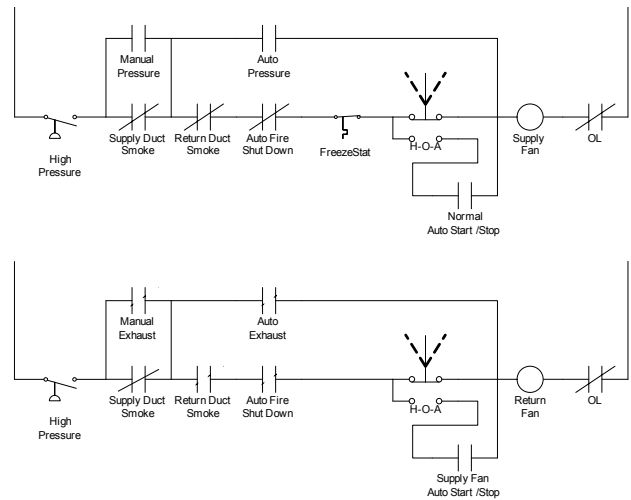

Notes:

- Pressure cutouts, duct smoke detectors and auto shutdown are 2-pole.
- Manual control also activates "auto control" relays.

The ABB E-Clipse Bypass also includes a second, programmable, override input. Override 2 is completely user programmable to allow the system integrator to configure the unit to acknowledge some digital inputs, all digital inputs, ignore digital inputs, or any combination of the above. This programmability allows the smoke control system integrator to program the ABB E-Clipse Bypass to react in whatever manner the local Authority Having Jurisdiction (AHJ) requests. Override 2 may be programmed to run until destruction or to acknowledge high-priority safeties and not acknowledge other, lower priority safeties.

The user may also force the unit into Override 2 mode via serial communications, while Smoke Control override only responds to an input on Digital Input 6.

Both Override modes are clearly annunciated on the bypass keypad, as well as acknowledged over serial communications. Both Override modes ignore any user input from either the VFD keypad or the bypass keypad. Both Override modes also respond to manual inputs from the Fireman's Smoke Control Panel (FSCP). Finally, both Override modes are designed so that, when the override input is removed, the system returns to its previous operating state.

[Return to Brochure](#)



## Stand-Alone Operation

The ABB E-Clipse Bypass allows for stand-alone operation of your system in several modes. First, most connections to the outside world are made into the bypass section of the system. These connections include start / stop command, safety interlocks, run permissive and serial communications. Therefore, removal of the VFD for service or replacement does not hinder the operation of your fan or pump system.

Even with the VFD removed, the same start / stop contact that was starting the system in drive mode can now start the system in bypass mode. In addition, because the ABB E-Clipse Bypass keypad has Hand and Off functions, local control of the system in bypass mode is as easy as the push of a button.

The bypass serial communications connection allows the user to monitor all of the bypass digital inputs and monitor and control all of the bypass digital (relay) outputs in a stand-alone mode.

If the VFD is taken out of service for any reason, the building management system is still communicating with the bypass controller system. Therefore, transfer to bypass no longer means losing control! In the past, if the VFD power was removed, the application would show as a failed point on the serial communications network. With the ABB E-Clipse Bypass, the drive can be removed and sent back to the factory for service (for example) with no loss of communications to the building management system.

The user can also monitor motor volts, amps, kilowatt hours and much more information - even in the bypass mode. In all, over 45 points of bypass information is transmitted between the bypass controller and building management system. Bypass relay outputs can be controlled via the serial link to accomplish such tasks as starting exhaust fans, or opening interlock dampers. Finally, the bypass also includes a supervisory controller which allows one to maintain on/off control of your cooling tower or pump application - even with the VFD in a faulted state.



[Return to Brochure](#)

## Advanced Plain-English Bypass Keypad

The new ABB E-Clipse Bypass keypad takes the typical operator interface to a new level. The ABB E-Clipse Bypass series keypads use full language, not cryptic codes. Using the intuitive interface, you can custom configure your bypass for a variety of applications and functions. This new keypad has pioneered several new-to-the-market features such as individual safety annunciation and the capability of allowing the user to choose the English to be displayed on the keypad. For example, the user can choose between eight different English phrases to display if a safety contact input to the bypass opens. The keypad can be programmed to display “FireStat”, “FreezeStat”, “Vibration Trip”, and five other choices. The user may also select from three pre-programmed English displays for the run-permissive proof. For example, the user can have the display read “Damper End Switch” if the run-permissive is not made.

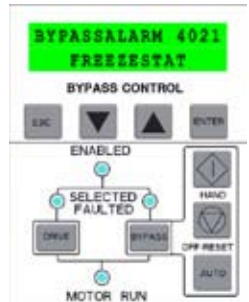

This keypad also provides superior system diagnostics. If the bypass were to trip off line for any reason, the fault is displayed in plain English, telling the user what has occurred. In addition, the fault is time stamped to allow the user to coordinate the fault diagnostics with external history logs. Finally, the keypad also contains an event log which may be useful in developing causal connections between any faults and user/operator events.

Carried over from the current E-bypass operator panel design are the status LED indicators and the one-line power flow diagram. These features provide visual indication of the system status and operating mode. For example, if a safety is open, the enabled LED will display red in color and can easily be seen from across the room, annunciating the condition.

The new ABB E-Clipse Bypass has added a two-line, 16 character LCD display to the keypad LEDs and selectors. The keypad allows sophisticated yet simple user interface for programming advanced functionality such as serial communications, supervisory control, or individual safety annunciation into the system.

The ABB E-Clipse Bypass comes out of the box ready to run. The user does not need to use the advanced keypad functions if they do not require advanced operation. A standard VFD start-up is all that needs to be accomplished. The bypass controller reads the motor full load amp settings entered into the VFD during start up and uses those settings to set the UL-listed motor overload protection in the E-Clipse Bypass. Therefore, sophisticated, yet simple control is available at your fingertips.

[Return to Brochure](#)

## Individual Safety Annunciation

The ABB E-Clipse Bypass allows for individual naming of safety inputs into the system. The user may choose from a predefined list of eight different safety names for display on the keypad. With programming by the BAS system vendor, the same names may be displayed on the BAS system master controller. For example, one digital input may be assigned the name FireStat. Another digital input may be programmed to display FreezeStat.







The list of programmable, predetermined annunciations for safety inputs is as follows:

- FireStat
- FreezeStat
- Smoke Alarm
- Vibration Trip
- Over Pressure
- Low Suction
- Vibration Switch
- Safety Open
- Factory default = Start Enable 1; Start Enable 2; Start Enable 3; or Start Enable 4

In addition, the run-permissive receipt proof has a predefined list of available names. The user may choose from the following list of annunciations to be displayed on the keypad for the Run Enable input:

- Damper End Switch
- Pre – Lube Cycle
- Valve Open
- Factory default = Run Enable

From the above, one can see that the ABB E-Clipse Bypass and its on-board microprocessor allow for previously unheard of diagnostics and information display. In addition to the above-listed keypad displays, the ABB E-Clipse Bypass will display all system warnings and system faults. The system also includes event and fault time-stamping information that will allow the end user to determine exactly when a fault condition occurred and if the fault condition was precipitated by a user input (event).

| Safety  |                   |
|---|-------------------|
|   | FireStat          |
|  | FreezeStat        |
|  | Smoke Alarm       |
|  | Vibration Trip    |
|  | Over Pressure     |
|  | Low Suction       |
| Run Permissions   |                   |
|   | Damper End Switch |
|   | Valve Opening     |
|   | Pre-Lube Cycle    |

[Return to Brochure](#)